

# Faraday Cup (uncooled version)

Type DF 060

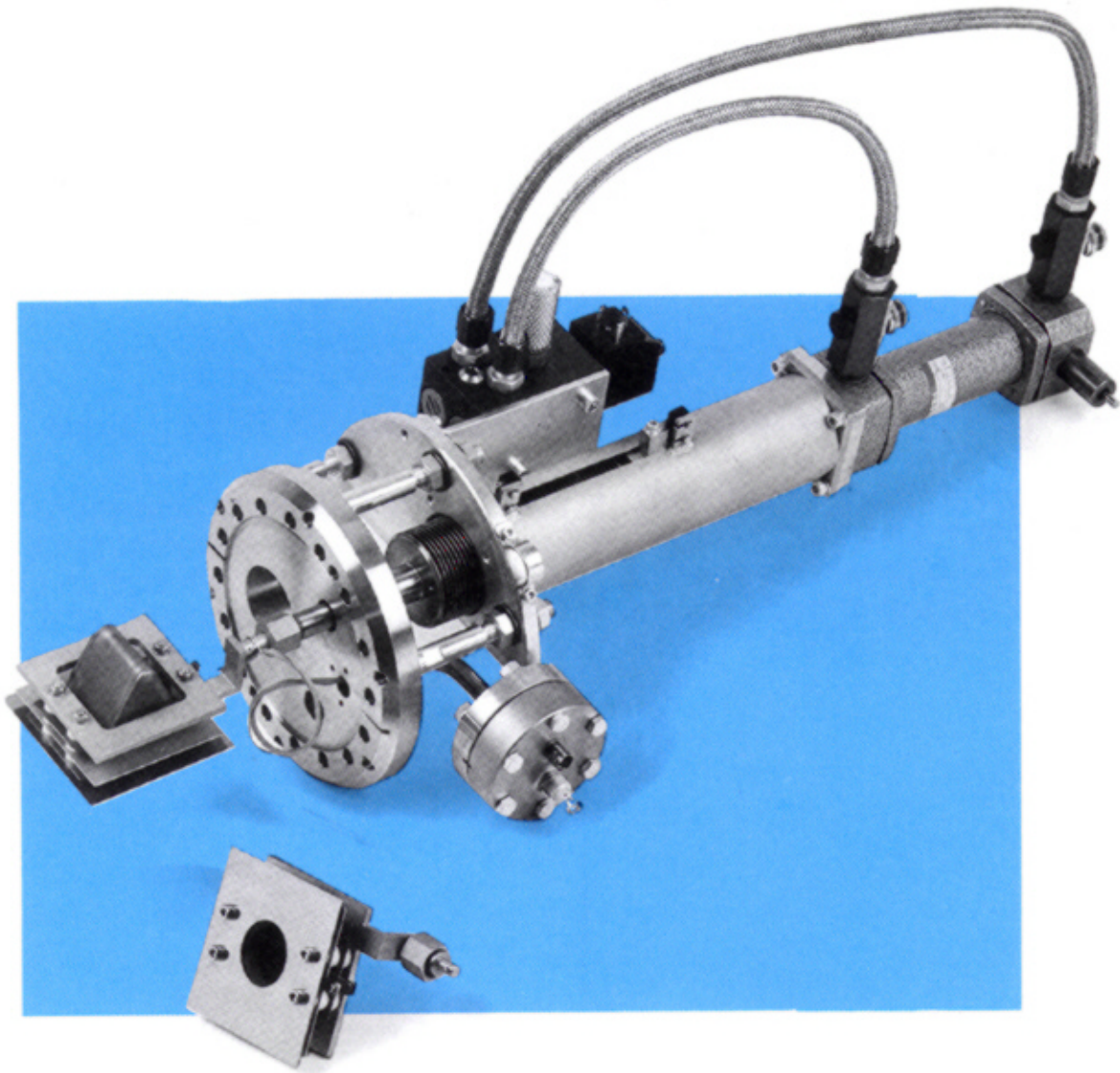

**PRINCETON SCIENTIFIC CORP.**

P.O. Box 143

Princeton, NJ 08542

Tel: (609) 924-3011 Fax: (609) 924-3018

## **FARADAY CUP (uncooled version)**

### **Application:**

Measurement of mean beam current of particle accelerator.

### **Principle:**

The accelerated particles are stopped inside cup and the accumulated electric charge is detected as a corresponding electric current. The Faraday Cup can be moved into the beam by means of a compressed air actuated vacuum feedthrough.

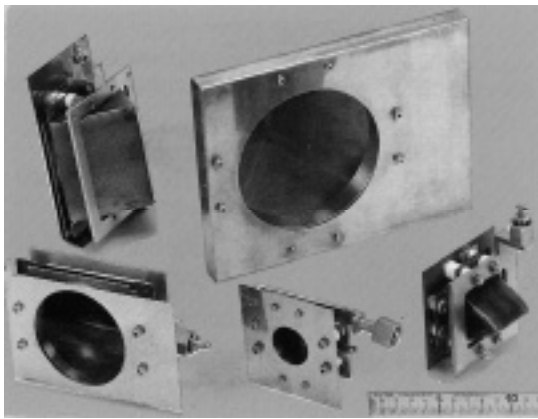

**Fig. 1**

Selection of uncooled Faraday Cups with various apertures. Specifications correspond to DF 060. Cups can be attached to DL 060 feedthrough.

### **Technical Specifications (standard version):**

<b>Material</b>	:	Tantalum (cup and shield) Stainless steel (cup frame) Ceramics (cup insulation; suppressor electrode insulation)
<b>Diameter of cup aperture</b>	:	1.2 inches
<b>Cup shape</b>	:	Conical
<b>Beam power (maximum)</b>	:	600 Watts
<b>Connector for current signal</b>	:	BNC
<b>Suppression of secondary particles</b>	:	By electric field.
<b>Connector (high voltage for suppressor electrode)</b>	:	BNC (HV)
<b>High voltage (maximum)</b>	:	2500 V
<b>Insulation</b>	:	1 GOhms
<b>UHV feedthrough</b>	:	DL 060 (reference specifications for DL 060)

*Cover Photograph: Uncooled Faraday Cup, standard version DF 060, attached to an UHV Feedthrough DL 060.*

**NOTE:** If specifications for cup aperture are to be increased in size, it should be taken into account that with increasing aperture, secondary electron suppression becomes more and more ineffective if the length of suppression electrode is not increased.

Improvement of secondary electron suppression (for example, by use of permanent magnets) should be discussed as a separate consideration when reviewing each application of our DF 060 Faraday Cup.

**Technical Specifications (Standard Actuator):**

<b>Compressed air control</b>	:	Solenoid valves 24 V d.c., 0.5 A
<b>Damping</b>	:	Adjustable
<b>Lock-in in the event of pressure drop</b>	:	Special mechanism holds feedthrough in "out" position.
<b>Sealing of 'in' and 'out' motion</b>	:	Membrane bellow
<b>Maximum leak rate</b>	:	$10^{-10}$ Torrs x liters/second
<b>Bakeout</b>	:	Up to 150° C
<b>Adjustment</b>	:	Plate with three (3) adjustable bolts
<b>Positioning of feedthrough on the vacuum chamber</b>	:	Optional
<b>Mounting of the unit</b>	:	Standard bolts
<b>Cooling of attached elements</b>	:	Possible (optional)

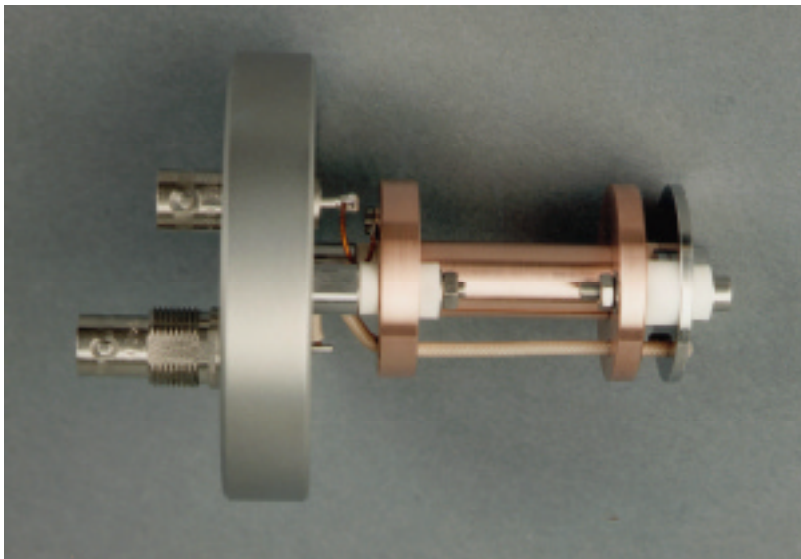

**Fig. 2**

Uncooled Faraday Cup (End Cup), maximum beam power level 100 W, conflat flange

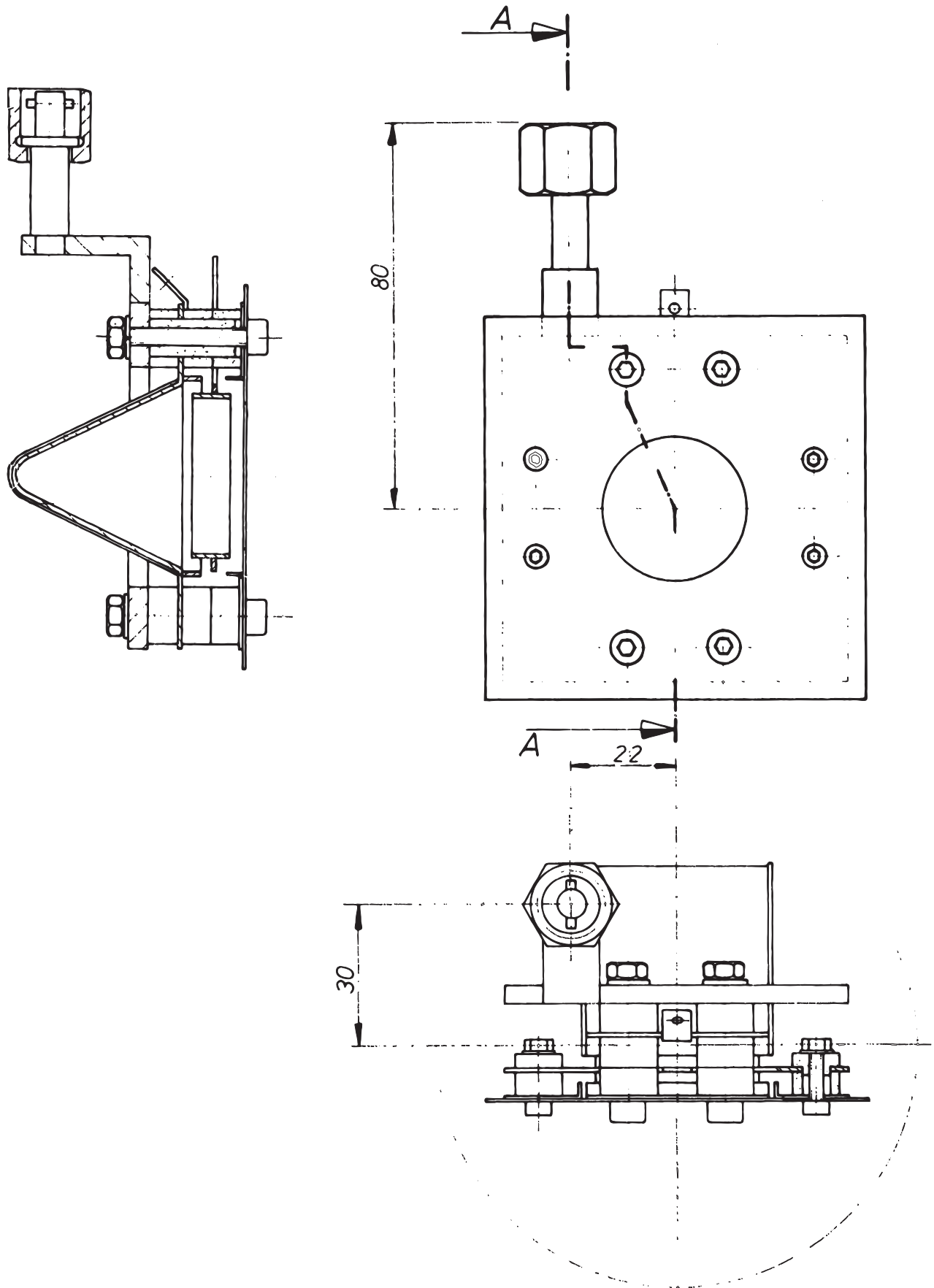

All Dimensions in Millimeters

Type DF060